

TECHNICAL DATA

DS 671	
Product Type	Compact Panel PC
General characteristics	
Processor	Intel® mobile Core™ i5/i3 fan
Chipset	Intel® HM55
Memory	1GB to 4GB DDR 3 SDRAM
Expansion slots	1 PCIe x16 slot 1 PCIe Mini card slot
Operating systems	Microsoft Windows XP/7/8/10
Power Supply	90 - 264 VAC auto range 24VDC optional ¹
Nominal Power	100 W, efficiency up to 88% ¹
Guarantee	24 Months ²
Drives	
Mass Memory	2,5" HDD at 60 GB (optional Flash Memory)
Optical Drives	optional DVD/CD-RW drive, rear side operation
Additional Drives	Compact Flash reader on slot optional
Interfaces	
LAN/Ethernet	Dual PCIe GbE controller
USB	5 x USB 2.0 (4 x external, 1 x internal)
Serial Interface	1 x RS232 (ext), 1 x RS -232/422/485 (int)
Display	1 free VGA port (dual display architecture)
Multimedia	Mic in, Line out
Watchdog Functions	
CPU Temperature	Surveillance onboard, auto throttling control when CPU overheats
Fan rotation	Surveillance onboard
Ambient Conditions	
Vibration resistance	0,67G (5-500Mhz)
Shock resistance	300G/2ms
EMC	EN 55011, 55022, 500081
Temperature	+5°C to +45°C max.
Relative humidity	5% to 80% at 25°C (no humidity/condense)
Authorization	CE
Mechanical Characteristics	
PC Unit	Powder coated, EMC proofed

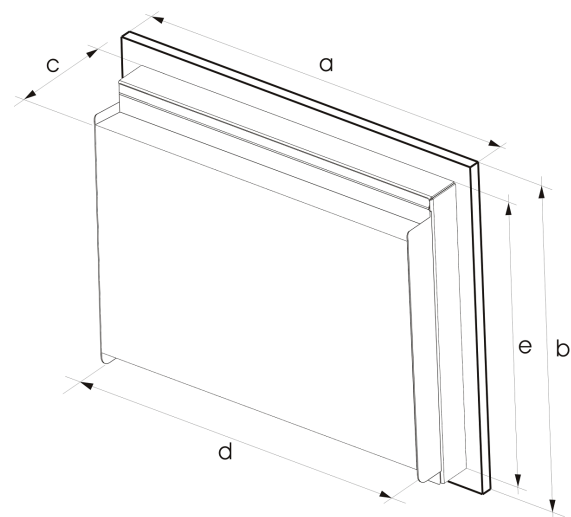

Front Unit				
	12"	15"	19"	21"
Display diagonal size	30,5 cm	38,1 cm	48,3 cm	54,1 cm
Resolution	800x600	1024x768	1280x1024	1600x1200
Luminosity [cd/m ²]	400	430	300	250
Contrast Ratio	500:1	450:1	800:1	500:1
MTBF backlight [h]	50.000			
Input	Resistive Touchscreen, 6-wire technology			
Touchcontroller	USB Touchcontroller			
Front	Alloy anodised, chemical resistant polyester foil			
Rating	IP65 according EN 60529			
Dimensions [mm]				
a:	400	472	540	
b:	310	383	440	
c:	115	120	135	
d:	370	440	509	
e:	290	363	406	
Weight	ca. 10 kg	ca. 13kg	ca. 15kg	



¹ 21" version only for 230V, required power + 30W
² warranty ex works, normally 24 months, fixed at order.
 All data refer on print date, errors and changes excepted.

