

TECHNICAL DATA

DE 870	
Product Type	Compact embedded Panel PC
General characteristics	
Processor	Intel® mobile Core™ i5/i3 fan
Chipset	Intel® HM55
Memory	2GB to 4GB DDR 3 SDRAM
Expansion slots	1 PCIe x16 slot 1 PCIe Mini card slot
Operating systems	WES2009, WES7, WE8S
Power Supply	90 - 264 VAC auto range 24VDC optional ¹
Nominal Power	100 W, efficiency up to 88%
Guarantee	24 Months ²
Drives	
Mass Memory	Flash Memory SLC or MLC various sizes
Additional Drives	Compact Flash Reader, optional
Interfaces	
LAN/Ethernet	Dual PCIe GbE controller
USB	5 x USB 2.0 (4 x external, 1 x internal)
Serial Interface	1 x RS232 (ext), 1 x RS -232/422/485 (int)
Keyboard/Mouse	via USB
Display	1 free VGA port (dual display architecture)
Multimedia	Mic in, Line out
Watchdog Functions	
CPU Temperature	Surveillance onboard, auto throttling control when CPU overheats
Ambient Conditions	
Vibration resistance	15G
Shock resistance	50G
EMC	EN 55011, 55022, 500081
Temperature	+5°C to +45°C max.
Relative humidity	5% to 80% at 25°C (no humidity/condense)
Authorization	CE
Mechanical Characteristics	
PC Unit	Powder coated, EMC proofed

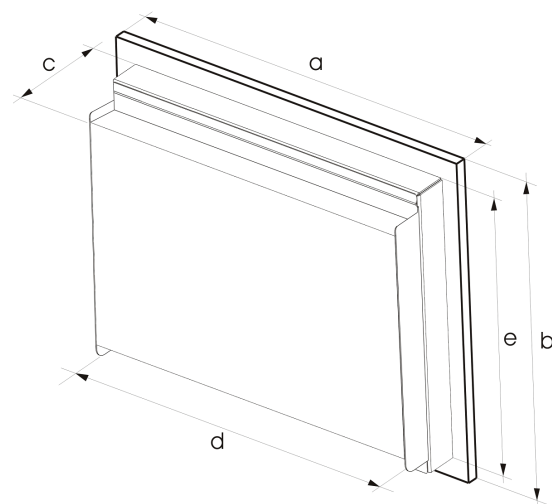

Front Unit				
Display diagonal size	12"	15"	19"	21"
	30,5 cm	38,1 cm	48,3 cm	54,1 cm
Resolution	800x600	1024x768	1280x1024	1600x1200
Luminosity [cd/m²]	400	430	300	250
Contrast Ratio	500:1	450:1	800:1	500:1
MTBF backlight [h]	50.000			
Input	Resistive Touchscreen, 6-wire technology			
Touchcontroller	Alternatively USB or RS232			
Front	Alloy anodised, chemical resistant polyester foil			
Rating	IP65 according EN 60529			
Dimensions [mm]				
a:	400	472	540	
b:	310	383	440	
c:	90	95	110	
d:	370	440	509	
e:	290	363	406	
Weight	ca. 10 kg	ca. 13kg	ca. 15kg	



¹ 21" version only for 230V, required power + 30W
² warranty ex works, normally 24 months, fixed at order.
 All data refer on print date, errors and changes excepted

HIGHLIGHTS

- Smart Fan system
- Intel® i3/i5 mobile possible
- Low mounting depth
- High power efficiency
- High performance
- Dual display architecture
- Dual LAN

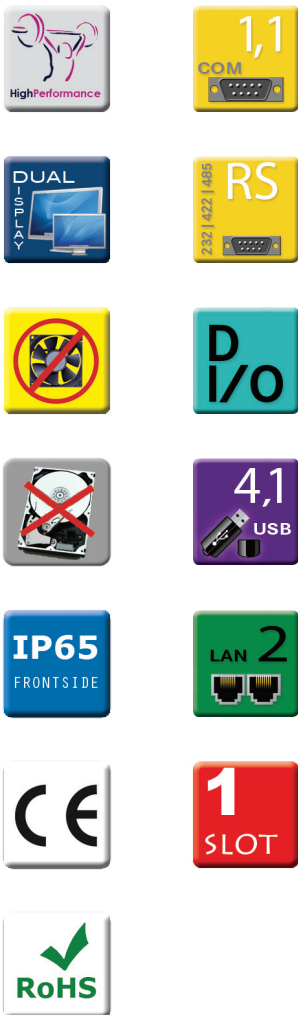

DE 870 CONFIGURATION

MONITOR

30,5 cm 12" TFT Display, 800x600 Pixel
38,1 cm 15" TFT Display, 1024x768 Pixel
48,3 cm 19" TFT Display, 1280x1024 Pixel
54,1 cm 21" TFT Display, 1600x1200 Pixel

PROCESSOR

Intel® mobile Core™ i3 fan
Intel® mobile Core™ i5 fan

MEMORY

2 GB
4 GB

STORAGE

Flash Memory SLC 4 GB
Flash Memory SLC 16 GB
Flash Memory MLC 32 GB ⁴
Flash Memory MLC >=60 GB ⁴

DRIVES

No drives
CFC-Adapter

POWER

110/230 VAC, auto-switch fanless
24 VDC fanless

FRONT

DIVUS foil
neutral, 1 colors
customized ¹

OPERATING SYSTEM

Microsoft WES 2009
Microsoft WE7E English - min. 8 GB Storage
Microsoft WE7P MUI - min. 16 GB Storage
Microsoft WE8S - min. 60 GB Storage

1	2	3	4	5	6	7	8
---	---	---	---	---	---	---	---

1							
2							
4							
5							

	5						
	6						

		5					
		6					

			6				
			8				
			9				
			X				

			0				
			1				

				1			
				2			

					0		
					1		
					2		

						S	
						T	
						U	
						V	

YOUR ORDER CODE: DE 870



NOTES:

- ¹ Frontfoil: min. delivery 25 pcs
- ⁴ SLC Drive on request

OPTIONAL

V₂A Stainless steel front available on 15" and 19" panels

